



Ref. 750

A		04
B		42
C		16
D		10
E		45
F		08
G		08
H		51
I		32
J		68

K		42
L		02
M		01
N		04
O		07
P		02
Q		02
R		08
S		02
T		01
U		01
V		05

Utilizar a régua abaixo para medir os componentes.

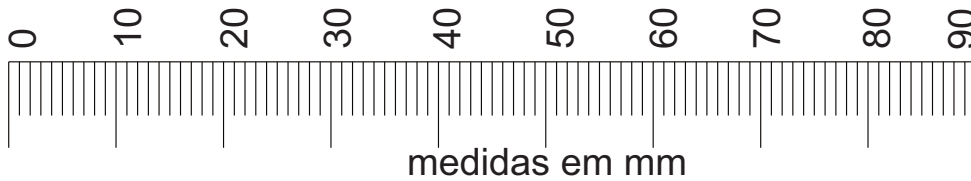

Nº Peça	Nome da Peça	Qtde
1	Tampo	01
2	Lateral Esquerda	01
3	Frente de Gaveta Inferior	01
4	Montantes Arredondados	04
5	Fundo	01
6	Distanciador Corrediça	02
7	Frente Gaveta Superior	01
8	Traseiro Gaveta	04
9	Traseiro Laterais	02
10	Fundo Gaveta	04
11	Distanciador de Dobradiça	01
12	Lateral Gaveta	08
13	Rodapé Frontal	02
14	Rodapé Lateral	02
15	Pé	04
16	Frente de Gaveta do Meio	02
17	Porta	01
18	Divisão	01
19	Lateral Direita	01
20	Traseiro Central	01
21	Travessa de Gaveta	04

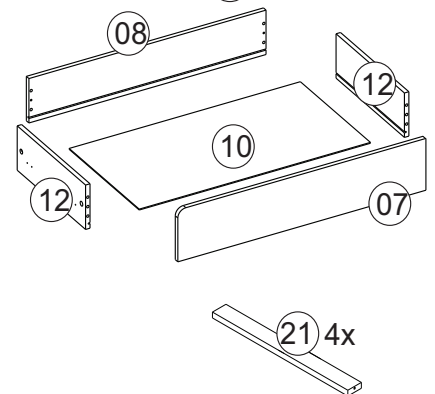
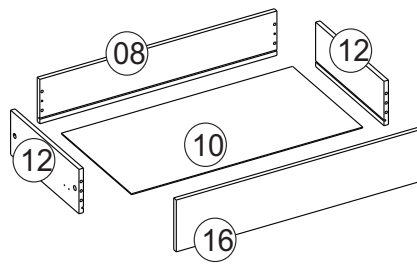
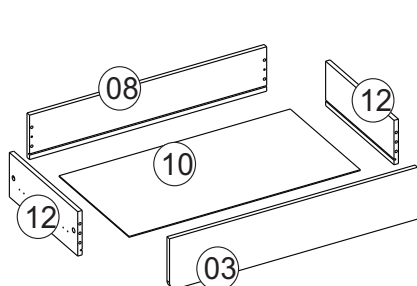
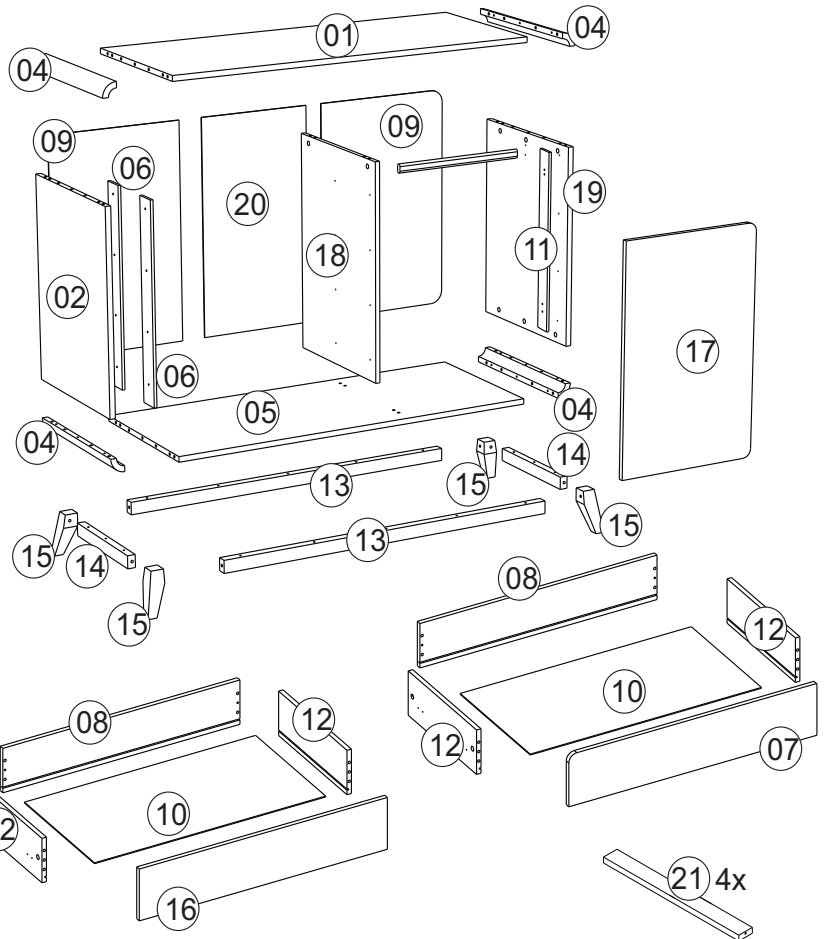

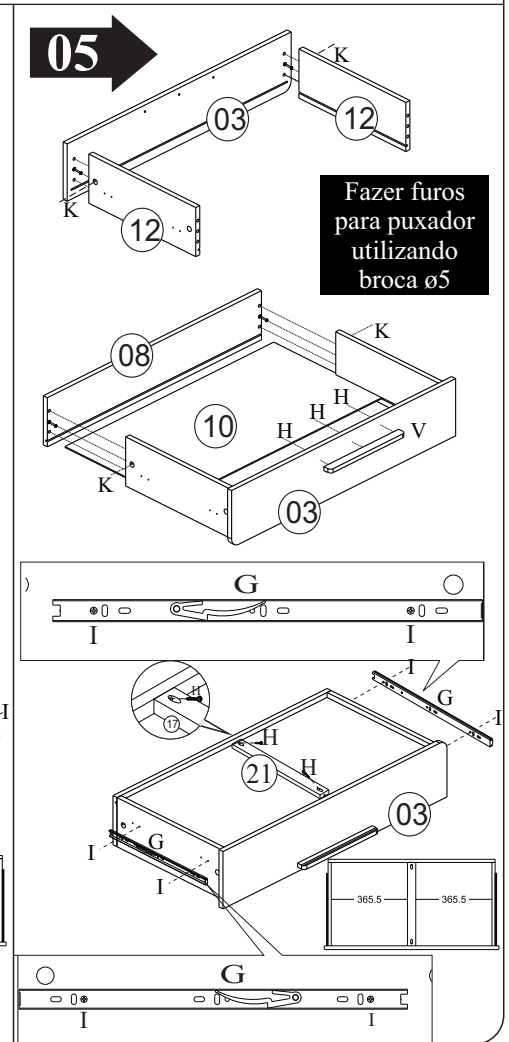
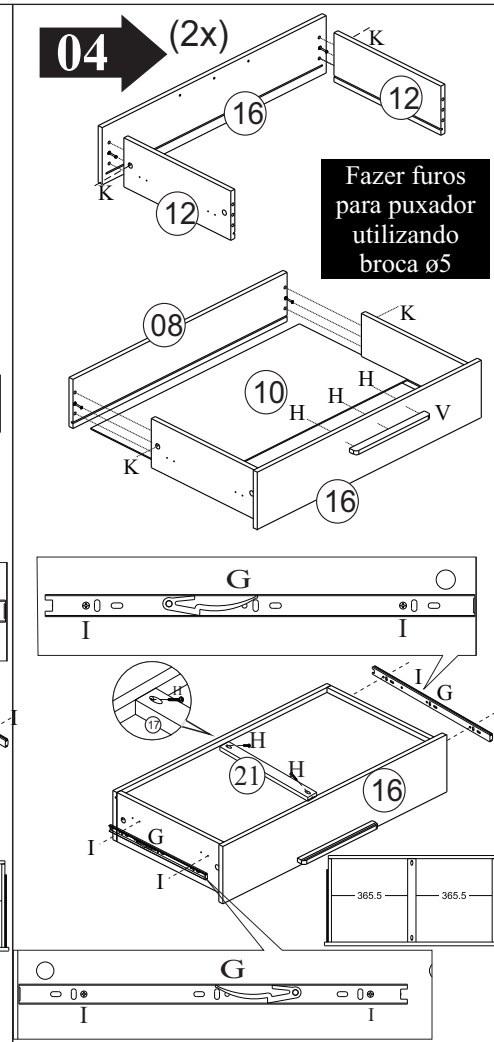
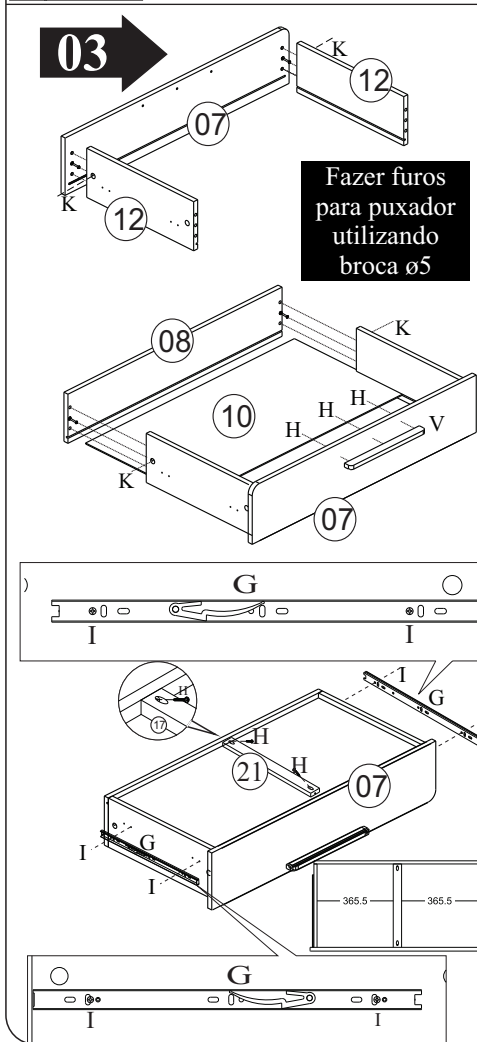
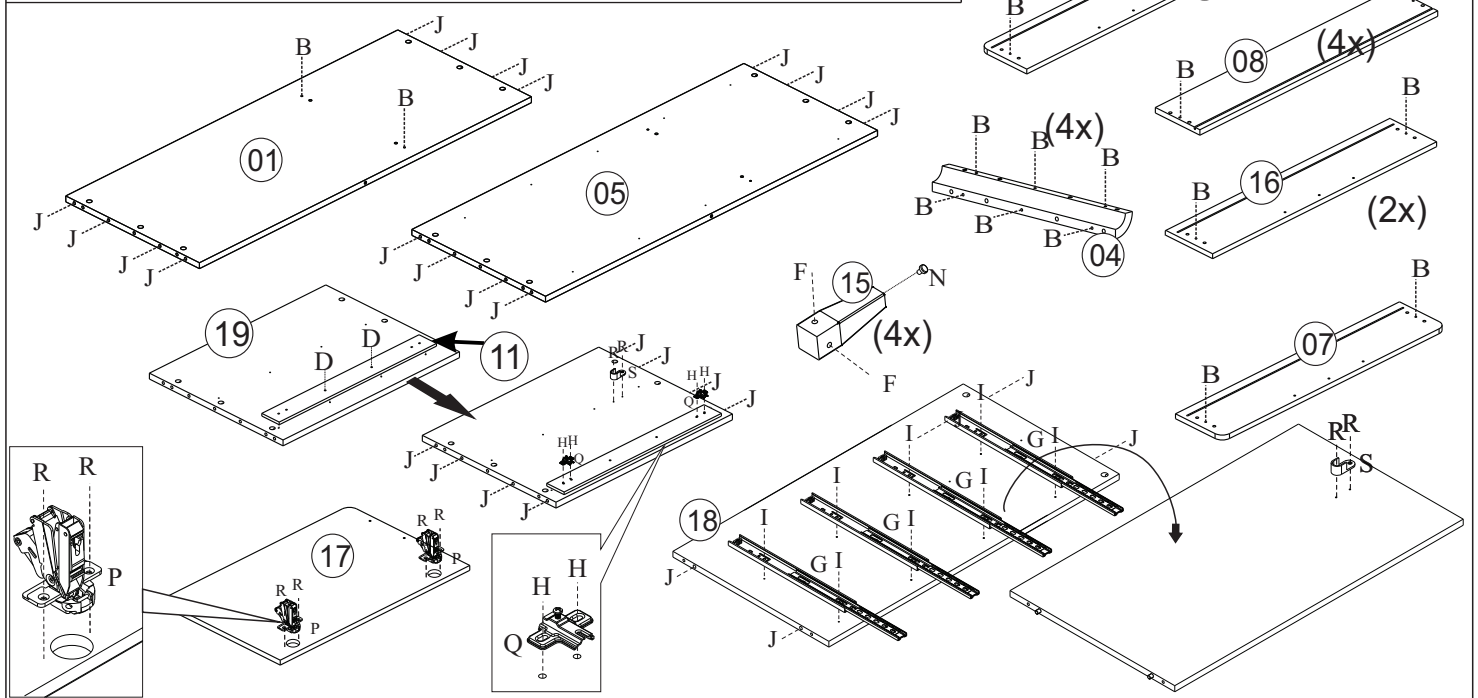
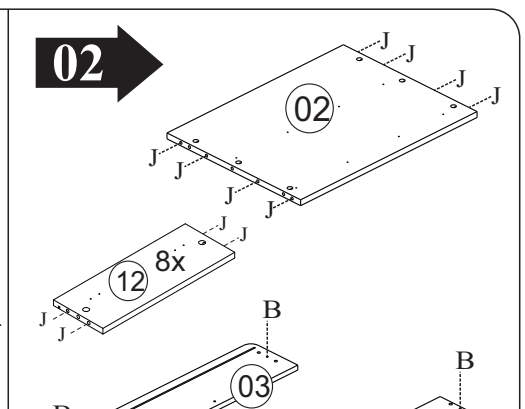
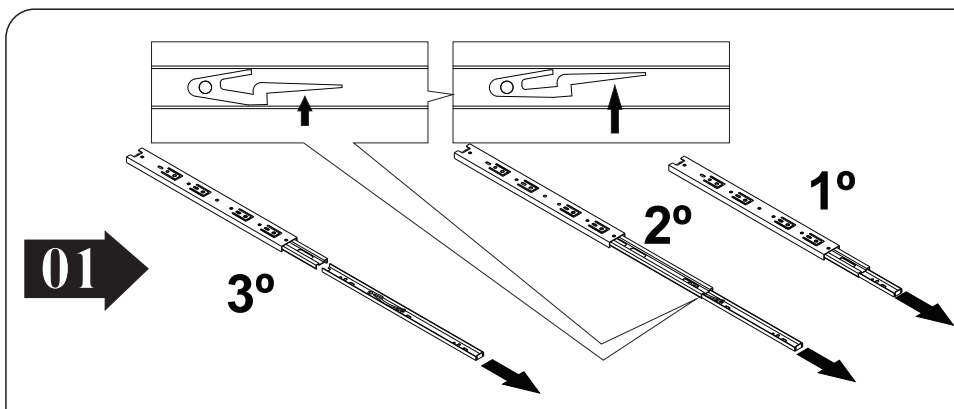

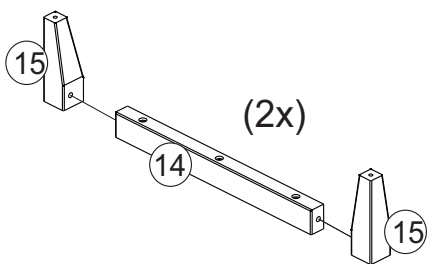
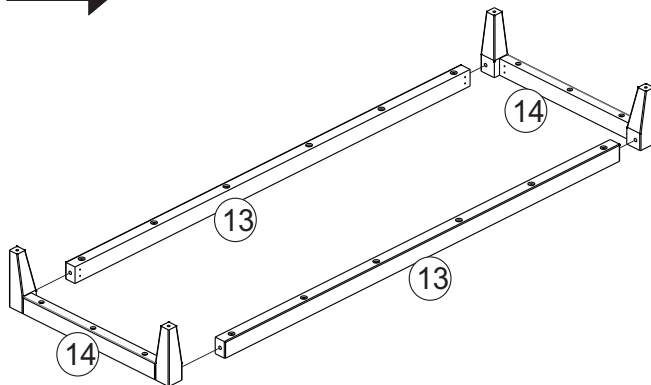
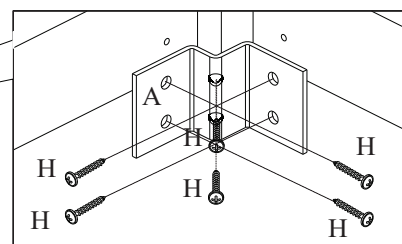
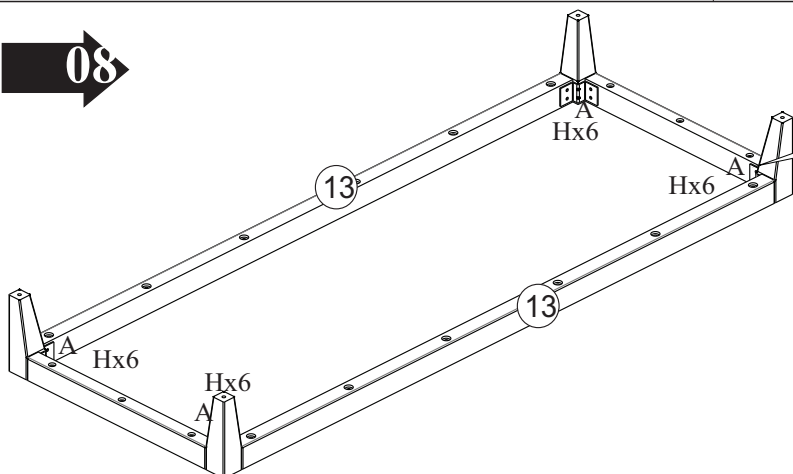
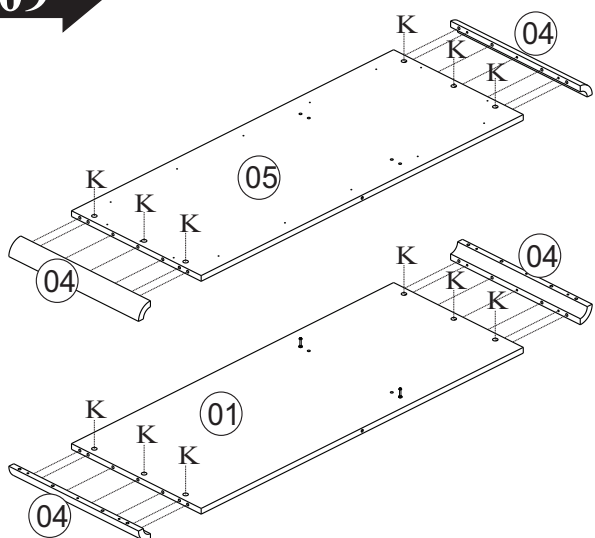
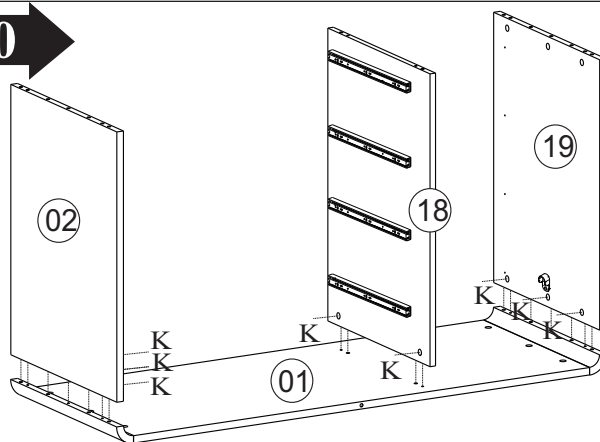
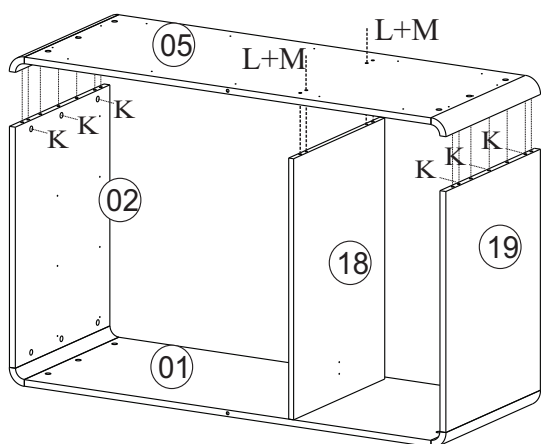
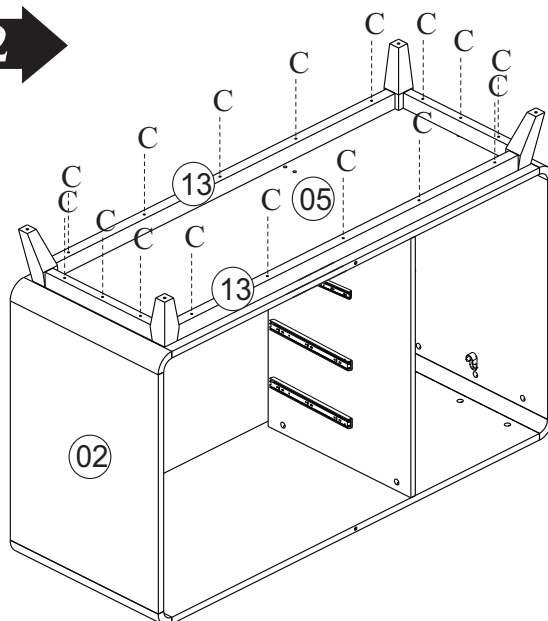
06**07****08****09****10****11****12**

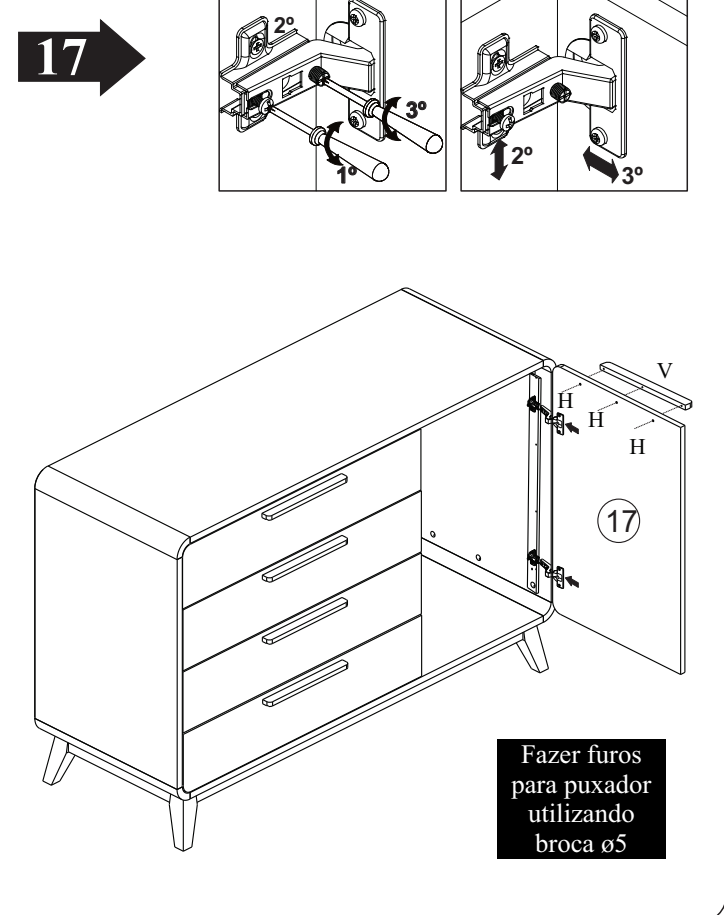
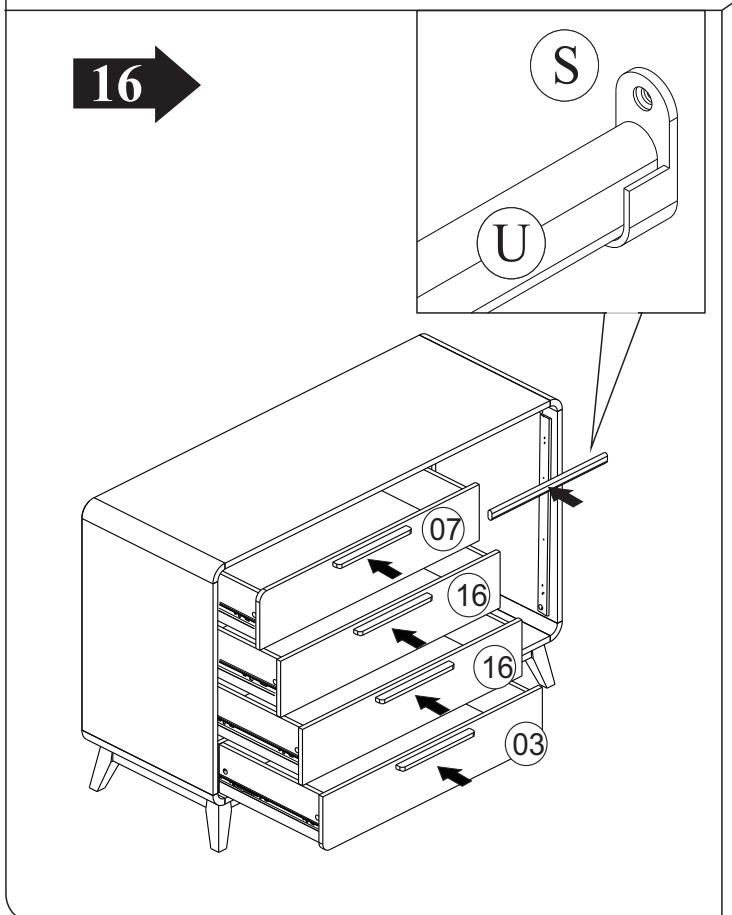
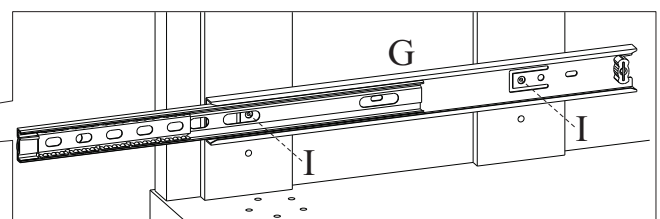
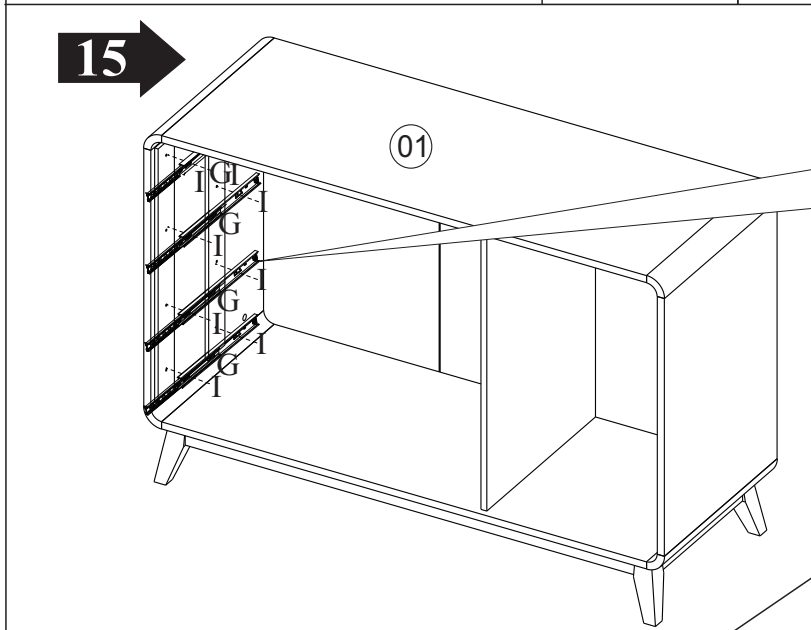
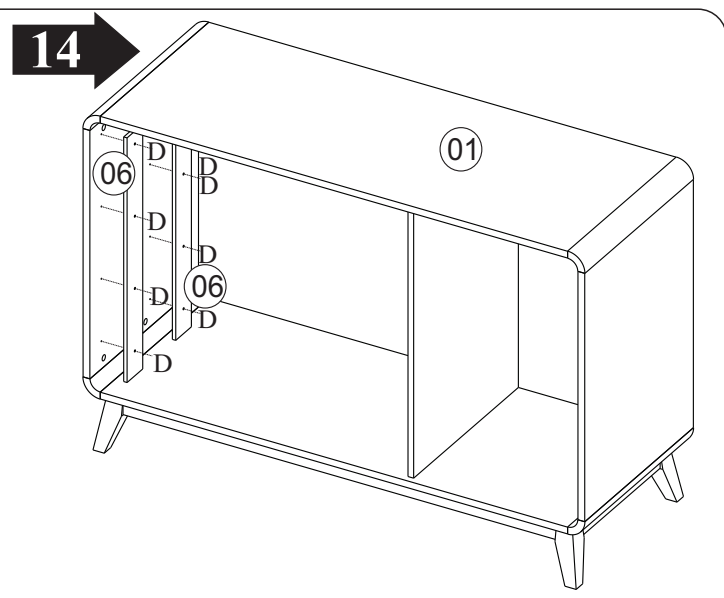
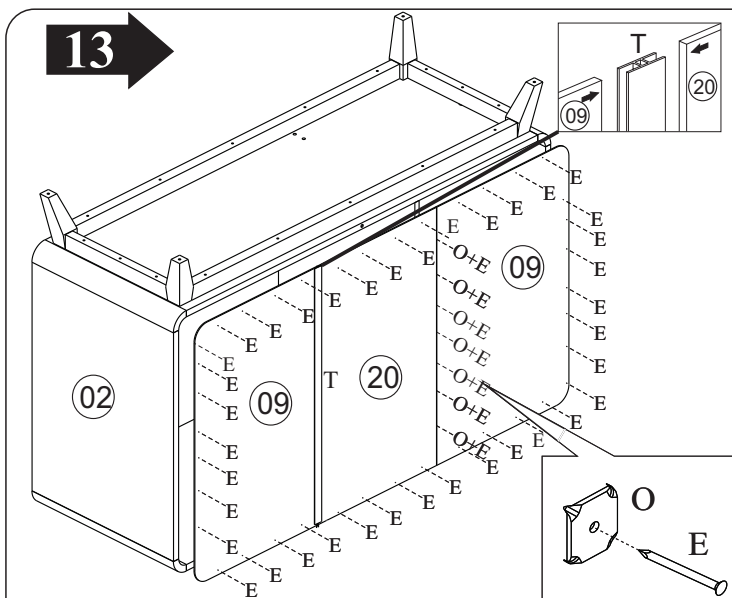

Fazer furos para puxador utilizando broca $\phi 5$